

## **INSTALLATION INSTRUCTIONS FOR LICHTGITTER CZ FIXING MATERIAL**

Gratings must be secured against rising or sliding off the supporting structure. Each grating should be fixed in at least four points, preferably in corners.

Fixing material from Lichtgitter CZ is available for all types of gratings and for all common and designed types of supporting structure profiles. The size of the upper part of fastening member (plate or upper clamp) and the length of bolt are adjusted to individual types of grids for which fastening material is supplied. Safety fastening members No. 3 and No. 6 and, in most cases, standard fastening member No. 1 are supplied as assemblies.

Unless otherwise stated, all types of fastening members, including bolts and nuts, are galvanized. The upper plates of fixing materials are provided with a hole in the recess for water draining and with moulded protrusions on the upper surface which help prevent slipping and also, when they are galvanized, a zinc coat with equal thickness is created on both sides of the plate. All types of fastening members are available with plastic pads.

### **STANDARD-FIXING MATERIAL B 133T/ B 133K**

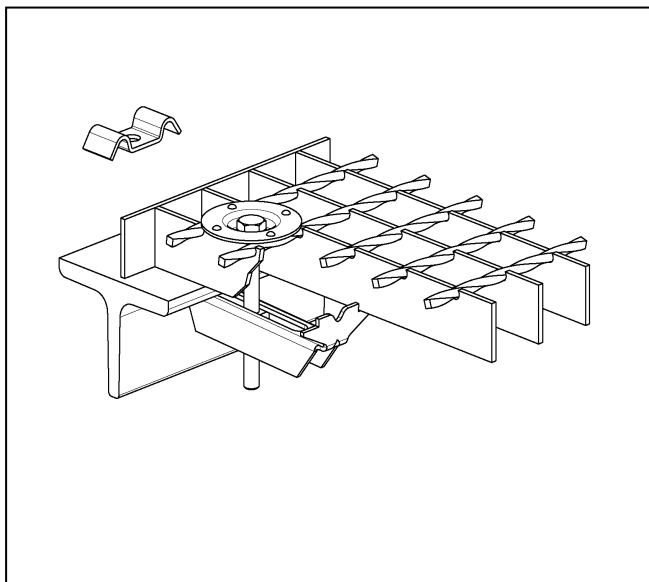

#### **Standard fixing material B 133T/ B133K**

Consisting of:

- clamp upper part or plate
- under part
- screw, nut and washer.

This fixing can be delivered in stainless steel, order-no. B 132T.

Length of screw must be at least height of grating plus 30 mm.

This fixing is suitable for pitches 33,33 x 33,33 mm or 34,33 x 38,1 mm.

The fixing can be assembled from above at a pitch onwards.

#### **Installation rules:**

- Position of the fixing material against the grating as seen in the figure.
- The bolt with plate must be placed as near to the beam as possible, preferably in the first whole free pitch of the grating.
- During installation, make sure that no part of the fixing material is distorted by tightening the bolted connection, i.e. neither the plastic pad nor the lower part of the fastening member.
- Tightening is performed using socket wrench No. 13.
- Depending on the conditions of use, all fixing materials must be inspected regularly and bolted connections tightened, if necessary.