

## INSTALLATION INSTRUCTIONS FOR LICHTGITTER CZ FIXING MATERIAL

Floor gratings must be secured against rising or sliding off the supporting structure. Each grating should be fixed in at least four points, preferably in corners.

Fixing material from Lichtgitter CZ is available for all types of floor gratings and for all common and designed types of supporting structure profiles. The size of the upper part of fastening member (plate or upper clamp) and the length of bolt are adjusted to individual types of gratings for which fastening material is supplied. Unless otherwise stated, all types of fastening members, including bolts and nuts, are galvanized. The upper plates of fixing materials are provided with a hole in the recess for water draining and with moulded protrusions on the upper surface which help prevent slipping and also, when they are galvanized, a zinc coat with equal thickness is created on both sides of the plate. All types of fastening members are available with plastic pads.

### HOOK SCREW-FIXING MATERIAL

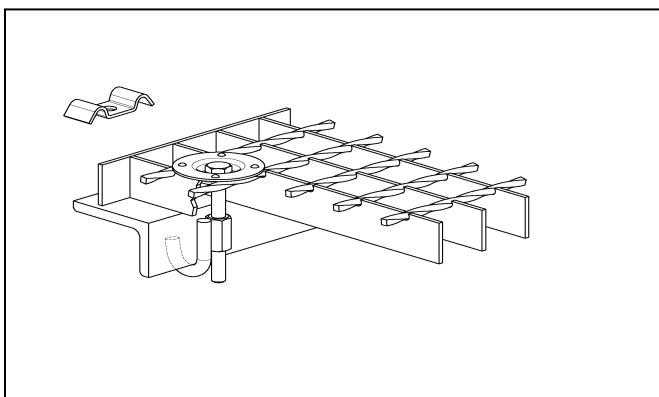

#### **Hook screw-fixing material suitable for L-profile B 733T or B 733K**

Consisting of:

- clamp upper part or plate
  - hook screw, adjusted to the underside support
  - screw M 8 x 90 mm, nut and washer.
- The size of hook is adjusted to dimension of rail cross-section.

This fixing material can be assembled from above.

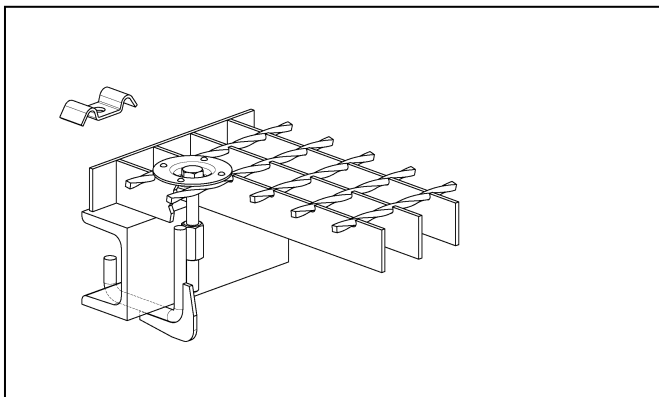

#### **Hook screw-fixing material suitable for U-profile B 833T or B 833K**

Consisting of:

- clamp upper part or plate
  - hook screw, adjusted to the underside support
  - screw M 8 x 90 mm, nut and washer.
- The size of hook is adjusted to dimension of rail cross-section.

This fixing material can be assembled from above.

#### **Installation rules:**

- Position of the fixing material against the grating as seen in the figure.
- During installation, make sure that no part of the fastening member is distorted by tightening the bolted connection, i.e. neither the plastic pad nor the lower part of the fastening member.
- Tightening is performed using socket wrench No. 13.
- Depending on the conditions of use, all fixing materials must be inspected regularly and bolted connections tightened, if necessary.